

THIS DOCUMENT IS THE PROPERTY OF RION TECHNOLOGY(SHENZHEN) LTD.(HEREAFTER"RION"),IT IS LENT AND IS TO BE RETURNED UPON REQUEST,THE CONTENTS OF THIS DOCUMENT ARE CONFIDENTIAL AND CONSTITUTE TRADE SECRETS PROPRIETARY TO RION,THIS DOCUMENT NOR ITS CONTENTS DOCUMENT NOR ITS CONTENTS SHALL BE DISCLOSED TO ANY UNAUTHORIAED PERSON COPIED OR PUBLISHED WITHOUT RION PRIOR WRITTEN CONSENT.
COPY RIGHT@2020 RION TECHNOLOGY

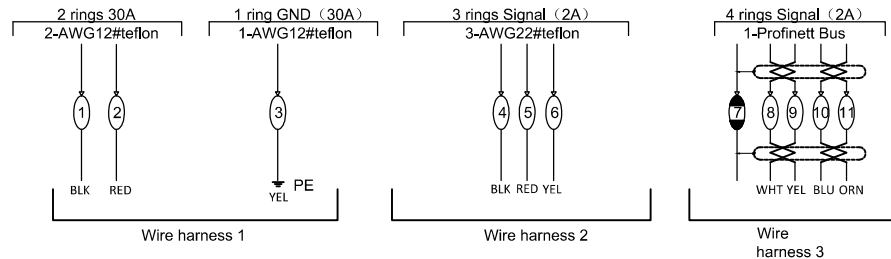
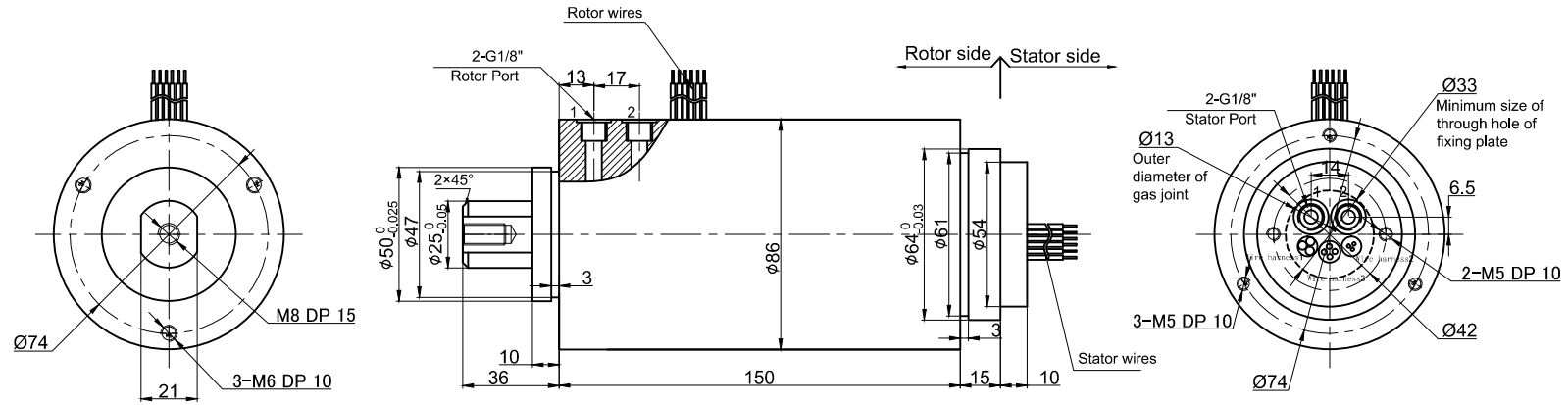

Technical parameters of rotary joint

1 Pressure	Max 1 Mpa	2 Passage	2 passage Gas
3 Texture of materia	Aluminium alloy	4 Tracheal connector	G1/8"
5 Media type	Compressed air		

Electrical Specification

1 Rings	11	2 Current	Power module:2 rings 30A+1 ring GND (30A) Signal module:3 rings Signal+1Profinett
3 Voltage	0-600VDC/VAC		
4 Insulation Resistance	500M Ω @500VDC		
5 Electrical noise	Max.10m Ω ;		
6 Dielectric strength	800VAC@50Hz;60S		

Mechanical Specification

7 Speed	0~250RPM;	8 Torque	Max.0.5 N.M;
9 Life	Typical :10million revolutions, but strongly depends on your working conditions		

Environmental adaptability

10 Working temperature	-30 $^{\circ}$ ~+80 $^{\circ}$ C	11 Storage temperature	-35 $^{\circ}$ ~+85 $^{\circ}$ C
12 humidity	85 \pm 3%(30 $^{\circ}$ C+5 $^{\circ}$ C)		
13 Rush	40g,11ms,Half sine wave, Vertical direction 3 times,Level 3times		
14 IP Class	IP51		

Material/Attachment

15 Contact Material	noble metal	16 Housing material	AL Alloy+ Carbon Steel
17 Lead wire	Rotor:300mm(See wiring diagram) Stator:300mm(See wiring diagram)		

UNLESS OTHERWISE SPECIFIED		2 passage Gas +2 rings 30A+1 ring GND (30A)+3 rings Signal+1Profinett	
1.ALL DIMENSIONS ARE IN MM HES BREAK SHARP EDGES &DEBURR		TOLERANCES (EXCEPT AS NOTED)	
2.MATERIAL&FINISH TO BE AS NOTED OR SUBSTITUTED WITH AN APPROVED AND TESTED EQUIVALENT		MODEL RX00812001	
FILLETS R.015 FINISH <input checked="" type="checkbox"/>		DECIMAL X \pm .1 XX \pm .03 XXX \pm .005	
THIRD ANGLE PROJECTION		SIZE A	
		R E V. A / 0	
		SCALE 1:1	
		UNIT mm	

